



European Medicines Agency

November 2000
CPMP/ICH/287/95

**ICH Topic E2B (M)
Clinical Safety Data Management: Data Elements for Transmission of Individual Case
Safety Reports**

Step 5

**NOTE FOR GUIDANCE ON CLINICAL SAFETY DATA MANAGEMENT: DATA
ELEMENTS FOR TRANSMISSION OF INDIVIDUAL CASE SAFETY REPORTS
(CPMP/ICH/287/95)**

TRANSMISSION TO CPMP FOR INFORMATION	November 2000
DATE FOR COMING INTO OPERATION	November 2000

**CLINICAL SAFETY DATA MANAGEMENT: DATA ELEMENTS FOR
TRANSMISSION OF INDIVIDUAL CASE SAFETY REPORTS**

TABLE OF CONTENTS

PREAMBLE.....	3
1. INTRODUCTION	3
1.1 Scope of this guideline	3
1.2 Background	3
1.3 Notes on format of this document	4
1.4 Definition of data elements	4
1.5 Minimum information	4
2. GUIDELINE: CONTENT OF THE DATA ELEMENTS	4
A. Administrative and Identification Information	5
A.1 Identification of the case safety report.....	5
A.2 Primary source(s) of information.....	8
A.3 Information on sender and receiver of case safety report.....	9
B. Information on The Case	10
B.1 Patient characteristics	10
B.2 Reaction(s)/event(s).....	14
B.3 Results of tests and procedures relevant to the investigation of the patient	16
B.4 Drug(s) information	17
B.5 Narrative case summary and further information	23
3. GLOSSARY	23
ATTACHMENT 1 Unit List and Definition of Interval List	24
ATTACHMENT 2 Route of Administration List.....	25
ATTACHMENT 3 Examples	26

Preamble

This revision provides additional information and clarification as well as some modifications of the E2B step 4 document signed off on July 17, 1997. It incorporates adjustments based on the successful pilot projects being conducted in the three regions. It is recommended that the reader reviews this document as well as the M2 ICSR Message Specification document version 2.3 . A new attachment 3 provides examples of the use of ICSR identifiers .

1. INTRODUCTION

1.1 Scope of this guideline

The objectives of the working group are to standardize the data elements for transmission of individual case safety reports by identifying, and where necessary or advisable, by defining the data elements for the transmission of all types of individual case safety reports, regardless of source and destination. This includes case safety reports for both pre and post approval periods and covers both adverse drug reaction and adverse event reports. It is not intended that this format should be used for cases in the integrated safety summary of a marketing license application dossier. For adverse reactions encountered in clinical trials, this format should be used only for those subject to expedited reporting. The scope of this topic does not encompass the definition of database structures, the design of a paper report form, quality control/quality assurance aspects, or technical security issues.

1.2 Background

Because of national and international agreements, rules, and regulations, individual case safety reports of adverse drug reactions and adverse events need to be transmitted (e.g., US 21CFR314.80):

- from identified reporting sources to regulatory authorities and pharmaceutical companies;
- between regulatory authorities;
- between pharmaceutical companies and regulatory authorities;
- within authorities or pharmaceutical companies;
- from clinical investigators, via the sponsor, to ethics committees;
- from authorities to the World Health Organization (WHO) Collaborating Center for International Drug Monitoring.

The transmission of such individual case safety reports currently relies on paper-based formats (e.g., yellow cards, CIOMS forms, MedWatch, ...) or electronic media (e.g. within pharmaceutical companies, or with WHO), usually by on-line access, tape or file transfer.

Considering the large number of potential participants in a world-wide exchange of information, there is a need for an electronic format capable of accommodating direct database to database transmission using message transfers.

Successful electronic transmission of information relies on the definition of common data elements, provided in this document, and standard transmission procedures to be specified by the ICH Electronic Standards for the Transfer of Regulatory Information (ESTRI) Expert Working Group (M2).

This document has taken into account the documents provided by ICH sponsors, the ENS-CARE Single Case Format, EuroSCaPE format, and the CIOMS IA proposal, and comments received following the circulation of these papers.

1.3 Notes on format of this document

Section 2 and its subsections designated A and B contain notes that are directed toward clarifying the nature of the data that should be provided. In addition, there are notes to assist in defining the format that should be used to transmit the data. In order to distinguish between these notes, the user guidances are presented in standard type of a slightly smaller font.

If a data element has a limited set of choices, they are presented in ***bold italic type***. The standard allows for this information to be transmitted in encoded format.

1.4 Definition of data elements

The format for individual case safety reports includes provisions for transmitting all the relevant data elements useful to assess an individual adverse drug reaction or adverse event report. The data elements are sufficiently comprehensive to cover complex reports from most sources, different data sets, and transmission situations or requirements; therefore, not every data element will be available for every transmission. In many, if not most instances, a substantial number of the data elements will not be known and therefore not included in the transmission. Where it was deemed important, provisions for unknown/not applicable were included (e.g., outcome, route of administration). However, since the transmission is intended to be electronic, it was thought to be unnecessary to include provisions to assign values of unknown for all data elements. Different ways of including the same data have been provided to cope with differing information contents: e.g., age information can be sent as date of birth and date of reaction/event, age at the time of reaction/event, or patient age group according to the available information (see section B.1.2 and the respective user guidance). In this example, age should be provided by the most precise available data element rather than including multiple elements of redundant data.

Structured data are strongly recommended in electronic transmission and provisions for including information in this way have been made. However, structuring of the data also implies the use of controlled vocabularies, which are not yet available for some data elements. Electronic transmission of individual case safety reports should be implemented with MedDRA where applicable. When MedDRA terms are used the version number should be provided. MedDRA terms should be provided as either text or code according to the regional preferences until January 2003 when codes will be used in all regions. In certain instances, there are provisions for the transmission of some free text items, including a full text case summary narrative. The transmission of other unstructured data, such as full clinical records or images is outside the scope of this guideline.

1.5 Minimum information

The minimum information for the transmission of a report should include at least one identifiable patient (section B.1), one identifiable reporter (section A.2), one reaction/event (section B.2), and one suspect drug (section B.4). Because it is often difficult to obtain all the information, any one of several data elements is considered sufficient to define an identifiable patient (e.g., initials, age, sex) or an identifiable reporter (e.g., initials, address, qualification). It is also recognized that the patient and the reporter can be the same individual and still fulfill the minimum reporting criteria.

In addition, to properly process the report, the following administrative information should be provided: the sender's (case) safety report unique identifier (A.1.0.1), the date of receipt of the most recent information (A.1.7), the worldwide unique case identification number (A.1.10).and the sender identifier (A.3.1.2).

2. GUIDELINE: CONTENT OF THE DATA ELEMENTS

The message content contains header information followed by E2B Data Elements. See the M2 ICSR Message Specification for information about the header.

The data elements are divided into sections pertaining to:

- A: Administrative and Identification Information
 - A.1 - Identification of the case safety report
 - A.2 - Primary source(s) of information
 - A.3 - Information on sender and receiver of case safety report
- B: Information on the Case:
 - B.1 - Patient characteristics
 - B.2 - Reaction(s)/event(s)
 - B.3 - Results of tests and procedures relevant to the investigation of the patient
 - B.4 - Drug(s) information
 - B.5 - Narrative case summary and further information

A. Administrative and Identification Information

A.1 Identification of the case safety report

A.1.0.1 Sender's (case) safety report unique identifier

User Guidance:

This identifier should remain constant in subsequent transmissions of the case by the same sender. Retransmitters should replace this value with their own unique identifier. The value should be a concatenation of "country code-company or regulator name-report number". Country code is the country of the primary source of the report (A.1.1). The company or regulator name is an internationally unique abbreviation or code for the sender's organisation. The report number is the organisation's international case number. Each component is separated from the other by a hyphen. For example a report transmitted by a company to a regulatory authority concerning a case from France would populate A.1.0.1 with "FR-companyname-12345" where 12345 is a company's unique case report number.

A.1.1 Identification of the country of the primary source

User Guidance:

Generally, this item would be the only country provided. Provisions have been made to include other countries for unusual cases concerning foreign travel and sources of manufactured material (A.1.2 and B.4.k.2.3). See the companion document for appropriate country codes.

A.1.2 Identification of the country where the reaction/event occurred

User Guidance:

For example, this should be the country where the reaction was detected while the patient was traveling, but the report was made by a health professional on the patient's return.

A.1.3 Date of this transmission

User Guidance:

A full precision date should be used (i.e., day, month, year)

A.1.4 Type of report

- *Spontaneous report*
- *Report from study*
- *Other*
- *Not available to sender* (unknown)

User Guidance:

A separate category for the designation of a literature source is covered in item A.2.2 and is not duplicated in this section which is intended to capture the type of report. If the case in the literature arises from spontaneous observations, “type of report” should be *Spontaneous report*. If the case arises from a study, “type of report” should be *Report from study*. If it is unclear from the literature report whether or not the case(s) cited are spontaneous observations or arise from a study, then this item should be *Other*.

Differentiation between types of studies (e.g. clinical trials or others should be given in section A.2.3.3).

The *Not available to sender* option allows for the transmission of information by a secondary sender (e.g., regulatory authority) where the initial sender did not specify the type of report; it differs from *Other* which indicates the sender knows the type of report but cannot fit it into the categories provided.

A.1.5 Seriousness

A.1.5.1. Serious

- *Yes/no*

A.1.5.2. Seriousness criteria (more than one can be chosen)

- *Results in death*
- *Is life-threatening*
- *Requires inpatient hospitalization or prolongation of existing hospitalization*
- *Results in persistent or significant disability/incapacity* (as per reporter's opinion)
- *Is a congenital anomaly/birth defect*
- *Other medically important condition*

User Guidance:

The terms *life-threatening* and *other medically important condition* are defined in the ICH E2A guideline. All the criteria apply to the case as a whole and should not be confused with the outcome(s) of individual reactions(s)/event(s) that are provided in section B.2.i.8. In addition section B.2.i.3 can be used to identify the seriousness of each reaction/event in accordance with the user guidance of the item.

A.1.6 Date report was first received from source

User Guidance:

For senders dealing with initial information, this should always be the date the information was received from the primary source. When retransmitting information received from another regulatory agency or another company or any other secondary source, A.1.6 is the date the retransmitter first received the information.

A full precision date should be used (i.e., day, month, year).

A.1.7 Date of receipt of the most recent information for this report

User Guidance:

Because reports are sent at different times to multiple receivers, the initial/follow up status is dependent upon the receiver. For this reason an item to capture follow-up status is not included. However, the date of receipt of the most recent information taken together with the “sender identifier” (A.3.1.2) and “sender’s (case) report unique identifier” (A.1.0.1) provide a mechanism for each receiver to identify whether the report being transmitted is an initial or follow-up report. For this reason these items are considered critical for each transmission.

A full precision date should be used (i.e., day, month, year).

A.1.8 Additional available documents held by sender

A.1.8.1 Are additional documents available?

- yes/no

A.1.8.2 List of documents held by sender

User Guidance:

The documents received from the primary source (e.g., clinical records, hospital records, autopsy reports) should be listed. It is recognized that these documents may not be obtainable in many instances.

A.1.9 Does this case fulfill the local criteria for an expedited report?

- yes/no

User Guidance:

The definition of expedited is dependent upon the local regulatory requirements. This item should be used by the sender to indicate if the case fulfills the local expedited requirements. When the countries of origin and destination of the transmission differ, the receiver should be aware that the information might not be applicable to their regulatory requirements.

A.1.10 Worldwide unique case identification number.

User Guidance:

Only A.1.10.1 or A.1.10.2 should be used. No case should ever have more than one of these items completed. The contents of whichever item is used should remain unchanged for any transmissions subsequent to the original transmission. When a regulator is the initial sender A.1.10.1 should be used. When an entity other than a regulator is the initial sender, A.1.10.2 should be used. When a sender has not previously received a valid E2B/M2 report electronically, the identifiers (content and format) in A.1.0.1 and A.1.10.1 or A.1.10.2 should be identical. Retransmitters should use their own sender’s (case) safety report unique identifier (A.1.0.1), but not change A.1.10.1 or A.1.10.2. See examples in attachment 3.

A.1.10.1 Regulatory authority’s case report number

A.1.10.2 Other sender’s case report number

A.1.11 Other case identifiers in previous transmissions

-yes

User Guidance:

This item should be completed only if the answer is yes.

A.1.11.1 Source(s) of the case identifier (e.g., name of the company, name of regulatory agency)

User Guidance:

This repeatable item should be used in conjunction with A.1.11.2 to provide all other case identifiers electronically transmitted, perhaps by multiple other senders. If the case has been received from another sender all other case identifiers included in A.1.11.1 and A.1.11.2 should be present. In addition the identifier of the previous sender (A.1.0.1) should be included here by the retransmitter. See examples in attachment 3.

A.1.11.2 Case identifier(s)

A.1.12 Identification number of the report which is linked to this report (repeat as necessary)

User Guidance:

This section should be used to identify reports or cases that warrant being evaluated together. This includes, but is not limited to, a mother-child pair where both had reactions/events, siblings with common exposure, several reports involving the same patient (e.g., a report sent via paper without a valid E2B/M2 electronic report identifier), several similar reports from same reporter (cluster). This item can also be used when a sender decides to create two or more ICSRs to provide individualised information on two or more suspect drugs in a single case (see B.2.i.7 and B.4.k.13). See examples in attachment 3.

A.1.13 Report nullification

-yes

User Guidance:

This item should be used to indicate that a previously transmitted report should be considered completely void (nullified), for example when the whole case was found to be erroneous. It is essential to use the same case report number previously submitted.

A.1.13.1 Reason for nullification

A.1.14 Was the case medically confirmed, if not initially from a health professional?

-yes/no

User Guidance:

This section should be completed if the primary source of information was a lawyer, consumer, or other non-health professional. It is important because of regional differences in regulations concerning lay reports.

A.2 Primary source(s) of information

The primary source(s) of the information is a person who reports the facts. This should be distinguished from senders (secondary sources) who are transmitting the information, (e.g., industry to regulatory authority).

Any or all of the three subsections (A.2.1, A.2.2., A.2.3) can be used. In the case of a published study or published individual case, the reporter would be the investigator or first author, and details on publication and trial type should also be provided.

A.2.1 Primary source(s) (repeat as necessary)

A.2.1.1 Reporter identifier (name or initials)

User Guidance:

The identification of the reporter may be prohibited by certain national confidentiality laws or directives. The information should be provided when it is in conformance with the regional confidentiality requirements and this guidance applies to all the subsections of A.2.1. Notwithstanding the above, at least one subsection should be completed to ensure there is an identifiable reporter. If only the name of the reporter is known and providing this name is prohibited because of confidentiality requirements, initials can be used.

A.2.1.2 Reporter's address

User Guidance:

See the companion document for format specifications.

A.2.1.3 Country

User Guidance:

See the companion document for format specifications.

A.2.1.4 Qualification

- *Physician*

- *Pharmacist*

- *Other health professional*

- *Lawyer*

- *Consumer or other non health professional*

User Guidance:

In some regions, consumer and lawyer reports should be transmitted only when there is medical confirmation.

A.2.2 Literature reference(s)

User Guidance:

References are provided in the Vancouver Convention (known as "Vancouver style") as developed by the International Committee of Medical Journal Editors. The standard format as well as those for special situations can be found in the following reference which is in the Vancouver style. International Committee of Medical Journal Editors. Uniform requirements for manuscripts submitted to biomedical journals. N Engl J Med 1997; 336:309-15.

A.2.3 Study identification

A.2.3.1 Study name

A.2.3.2 Sponsor study number

User Guidance:

This section would be completed only if the sender is the study sponsor or has been informed of the study number by the sponsor.

A.2.3.3 Study type in which the reaction(s)/event(s) were observed

- *Clinical trials*

- *Individual patient use; (e.g. "compassionate use" or named patient basis)*

- *Other studies* (e.g., pharmacoepidemiology, pharmacoconomics, intensive monitoring, PMS, etc.)

A.3 Information on sender and receiver of case safety report

A.3.1 Sender

A.3.1.1 Type

- *Pharmaceutical company*
- *Regulatory authority*
- *Health professional*
- *Regional pharmacovigilance center*
- *WHO collaborating center for international drug monitoring*
- *Other* (e.g. distributor, study sponsor, or contract research organization)

User Guidance:

In this context, a pharmaceutical company includes biotechnology companies and other manufacturers required to submit individual case safety reports.

A.3.1.2 Sender identifier

User Guidance:

Identifies the sender, (e.g., company name or regulatory authority name). This item should always be completed.

A.3.1.3 Person responsible for sending the report

User Guidance:

Name of person in the company or agency who is responsible for the authorization of report dissemination. This would usually be the same person who signs the covering memo for paper submissions. The inclusion of the name of this person in the transmission may be subject to national or international regulations.

A.3.1.4 Sender's address, fax, telephone and E-mail address

A.3.2 Receiver

User Guidance:

See the user guidance concerning the sender (A.3.1).

A.3.2.1 Type

- *Pharmaceutical company*
- *Regulatory authority*
- *Regional pharmacovigilance center*
- *WHO collaborating center for international drug monitoring*
- *Other* (e.g., a company affiliate or a partner)

A.3.2.2 Receiver identifier (see glossary)

A.3.2.3 Receiver's address, fax, telephone and E-mail address

B. INFORMATION ON THE CASE

B.1 Patient characteristics

User Guidance:

In cases where a fetus or suckling infant sustains an adverse reaction/event, information on both the parent and the child/fetus should be provided. Reports of these cases are referred to as parent-child/fetus report. Several general principles should be used for filing these reports. If there has been no reaction/event affecting the child/fetus the parent-child/fetus report does not apply. For those cases describing fetal demise or early spontaneous abortion, only a parent report is applicable. If both the parent and the child/fetus sustain adverse events, two reports should be provided but they should be linked by using sections A.1.12 in each of the reports. When only the child/fetus has an adverse reaction/event (other than early spontaneous abortion/fetal demise) the information provided in this section applies to the child/fetus, and characteristics concerning the parent who was the source of exposure to the drug should be provided in section B.1.10.

B.1.1 Patient (name or initials)

User Guidance:

The identification of the patient may be prohibited by certain national confidentiality laws or directives. The information should be provided when it is in conformance with the confidentiality requirements. This also applies to medical record number(s) (B.1.1.1).

B.1.1.1 Patient medical record number(s) and the source(s) of the record number (if allowable)

User Guidance:

Record numbers can include the health professional record(s) number(s), hospital record(s) number(s), or patient/subject identification number in a study. The source of the number should be specified to ensure the possibility of retrieval when possible and desirable.

B.1.2 Age information

User Guidance:

Only one of the elements describing age should be used. The choice should be based upon the most precise information available.

B.1.2.1 Date of birth

User Guidance:

A full precision date should be used (i.e., day, month, year). If the full date of birth is not known an approximate age can be used in section B.1.2.2.

B.1.2.2 Age at time of onset of reaction/event

User Guidance:

If several reactions/events are in the report, the age at the time of the first reaction/event should be used. For fetal reaction(s)/event(s) the next item B.1.2.2.1 "Gestation period when reaction/event was observed in the fetus" should be used.

When providing the age in decades, please note that, for example, the 7th decade refers to a person in their 60's.

See the companion document for format specifications.

B.1.2.2.1 Gestation period when reaction/event was observed in the fetus

User Guidance:

The gestation period at the time of exposure is captured in section B.4.k.10.

See the companion document for format specifications.

B.1.2.3 Patient age group (as per reporter)

-Neonate

-Infant

-Child

-Adolescent

-Adult

-Elderly

User Guidance:

The terms are not defined in this document and are intended to be used as they were reported by the primary source. This section should be completed only when the age is not provided more specifically in sections B.1.2.1 or B.1.2.2.

B.1.3 Weight (kg)

User Guidance:

The weight at the time of the event/reaction.

B.1.4 Height (cm)

B.1.5 Sex

User guidance:

See the companion document for format specifications.

B.1.6 Last menstrual period date

User guidance:

Imprecise dates can be included, (i.e., month, and year or year only). See the companion document for format specifications.

B.1.7 Relevant medical history and concurrent conditions (not including reaction/event)

B.1.7.1 Structured information on relevant medical history including onset and resolution date as well as relevant comments (repeat as necessary)

Disease / surgical procedure / etc.	Start date	Continuing Y/N/U	End date	Comments

User Guidance:

Medical judgment should be exercised in completing this section. Information pertinent to understanding the case is desired such as diseases, conditions such as pregnancy, surgical procedures, psychological trauma, etc. Each of the items in the table can be repeated as appropriate. If precise dates are not known and a text description aids in understanding the medical history, or if concise additional information is helpful in showing the relevance of the past medical history, this information can be included in the Comments column.

If applicable, MedDRA terms should be used in the main descriptive column for disease/surgical procedure/etc. Imprecise dates can be used for both start and end dates. See the companion document for format specifications for the continuing column.

B.1.7.2 Text for relevant medical history and concurrent conditions (not including reaction/event)

User Guidance:

If structured information is not available in the sender's database this item should be used. Otherwise, it is preferable to send structured data in segment B.1.7.1.

B.1.8 Relevant past drug history (repeat the line as necessary)

Name of drug as reported	Start date	End date	Indication	Reactions

User Guidance:

This segment concerns drugs previously taken, but not those taken concomitantly or drugs which may have potentially been involved in the current reaction(s)/event(s). Information concerning concomitant and other suspect drugs should be included in section B4. The information provided here can also include previous experience with similar drugs. Medical judgment should be exercised in completing this section. When completing the item concerning the name of the drug it is important to use the words provided by the primary source. Trade name, generic name or class of drug can be used. The term "none" should be used when appropriate, (e.g., when there is no previous exposure to the drug or vaccine, or no previous reaction following exposure).

If applicable, MedDRA terms should be used in the Indication and Reaction columns. Imprecise dates can be used for both start and end dates.

B.1.9. In case of death

B.1.9.1 Date of death

User Guidance:

An imprecise date can be used. See the companion document for format specifications.

B.1.9.2 Reported cause(s) of death (repeat as necessary)

User Guidance:

MedDRA if applicable

B.1.9.3 Was autopsy done?

Yes/No/Unknown

B.1.9.4 Autopsy-determined cause(s) of death (repeat as necessary)

User Guidance:

MedDRA if applicable

B.1.10 For a parent-child/fetus report, information concerning the parent

User Guidance:

This section should be used in the case of a parent-child/fetus report where the parent had no reaction/event. See user guidance for section B.1. Guidance regarding confidentiality is provided in B.1.1, and should be considered before providing the parent identification. For the subsections B.1.10.4 through B.1.10.8, the guidances provided for B.1.3 through B.1.5 and B.1.7 through B.1.8 should be reviewed.

B.1.10.1 Parent identification

B.1.10.2 Parent age information

User Guidance:

The date of birth should be used if the precise birthday is known; otherwise the age should be used.

B.1.10.2.1 Date of birth of parent

User Guidance:

A full precision date should be used. See the companion document for format specifications.

B.1.10.2.2 Age of parent

B.1.10.3 Last menstrual period date

User Guidance:

A full precision date should be used. See the companion document for format specifications.

If a precise date is not available, the gestation period at time of exposure in B.4.k.10 should be completed.

B.1.10.4 Weight (kg) of parent

B.1.10.5 Height (cm) of parent

B.1.10.6 Sex of parent

B.1.10.7 Relevant medical history and concurrent conditions of parent (not including reaction/event)

B.1.10.7.1 Structured information (parent)

Disease / surgical procedure/ etc.	Start date	Continuing Y/N/U	End date	Comments

B.1.10.7.2 Text for relevant medical history and concurrent conditions of parent (not including reaction/event)

B.1.10.8 Relevant past drug history of parent

Name of drug as reported	Start date	End date	Indication	Reactions (if any and known)

B.2 Reaction(s)/event(s)

User Guidance:

The designation of “i” in this section indicates that each item is repeatable and that it carries an appropriate correspondence to the same “i” in all subsections. A separate block (i) should be used for each reaction/event term. For example, if two reactions are observed, the first reaction would be described in items B.2.1.0 through B.2.1.8, and the other reaction would be described in items B.2.2.0 through B.2.2.8. The reaction/event specified in the first iteration should be the one used in assessing the intervals in B.4.k.13.

B.2.i.0 Reaction/event as reported by the primary source

User Guidance:

The original reporter's words and/or short phrases used to describe the reaction/event. (The original reporter's words and/or short phrases used to describe reaction/event can also be included in the narrative B.5.1).

B.2.i.1 Reaction/event in MedDRA terminology (Lowest Level Term)

User Guidance:

Only the MedDRA Lowest Level Term (LLT) most closely corresponding to the reaction/event as reported by the primary source should be provided.. In the exceptional circumstance when a MedDRA term cannot be found the sender should use good clinical judgment to complete this item with the best MedDRA approximation (see MedDRA™ TERM SELECTION:POINTS TO CONSIDER). MedDRA terms should be provided as either text or code according to the regional preferences until January 2003 when codes should be used in all regions. For international transmissions, English is the generally accepted language.

B.2.i.2 Reaction/event MedDRA term (Preferred Term)

User Guidance:

The term can be a sign, symptom or diagnosis. This also applies to the other items of structured data such as indication, diseases in past medical history, etc. MedDRA terms are to be provided as either text or code according to the regional preferences until January 2003 when codes should be used in all regions. For international transmissions, English is the generally accepted language.

B.2.i.3 Term highlighted by the reporter

1= Yes, highlighted by the reporter, NOT serious

2= No, not highlighted by the reporter, NOT serious

3= Yes, highlighted by the reporter, SERIOUS

4= No, not highlighted by the reporter, SERIOUS

User Guidance:

A highlighted term is a reaction/event that the primary source indicated was a major concern or reason for reporting the case. If the information is not explicitly provided by the initial reporter the term should not be considered a highlighted term. The seriousness of the reaction/event should be based on the ICH E2A criteria.

B.2.i.4 Date of start of reaction/event

User Guidance:

See the companion document for format specifications.

B.2.i.5 Date of end of reaction/event

B.2.i.6 Duration of reaction/event

User Guidance:

This section can usually be computed from start/end of reaction/event. Both dates and duration may be useful (e.g., for a reaction/event of short duration such as anaphylaxis or arrhythmia). Imprecise dates can be used. See the companion document for format specifications..

B.2.i.7 Time intervals between suspect drug administration and start of reaction/event

User Guidance:

The major uses of intervals are to cover circumstances where both the dates are known but the interval is very short (e.g., minutes, such as in anaphylaxis), and when only imprecise dates are known but more information concerning the interval is known. Dates if available should always be transmitted in the appropriate fields rather than intervals.

B.2.i.7 captures the interval between each reaction/event and only the first iteration of the drug in B.4.k. If there is more than one suspect drug and it is deemed critical, more than one ICSR can be used to provide all the intervals between each reaction/event and all suspect drugs. In this circumstance it is advisable to indicate the reports are linked in A.1.12. The complexity of the intervals highlights the desirability of providing dates. See the companion document for format specifications.

B.2.i.7.1 Time interval between beginning of suspect drug administration and start of reaction/event

B.2.i.7.2 Time interval between last dose and start of reaction/event

B.2.i.8 Outcome of reaction/event at the time of last observation

- recovered/resolved

- recovering/resolving

- not recovered/not resolved

-recovered/resolved with sequelae

-fatal

-unknown

User Guidance:

In case of irreversible congenital anomalies the choice, *not recovered/not resolved* should be used.

Fatal should be used when death is possibly related to the reaction/event. Considering the difficulty of deciding between "reaction/event caused death" and "reaction/event contributed significantly to death", both were grouped in a single category. Where the death is unrelated, according to both the reporter and the sender, to the reaction/event, death should not be selected here, but should be reported only under section B.1.9.

B.3 Results of tests and procedures relevant to the investigation of the patient

User Guidance:

This section should capture the tests and procedures performed to diagnose or confirm the reaction/event, including those tests done to investigate (exclude) a non-drug cause, (e.g., serologic tests for infectious hepatitis in suspected drug-induced hepatitis). Both positive and negative results should be reported. While structured information is preferable, provisions have been made to transmit the information as free text in B.3.2.

B.3.1 Structured information (repeat as necessary)

Date	Test	Result	Unit	Normal low range	Normal high range	More information available (Y/N)

User Guidance:

Imprecise dates can be used, units and normal ranges should be in free text unless covered by a controlled vocabulary. The column entitled "more information available" accepts only yes or no (see the companion document for the appropriate format). If results and units cannot be split, use B.3.2. More than one test can be included in B.3.2.

B.3.2 Results of tests and procedures relevant to the investigation

B.4 Drug(s) information

User Guidance:

This section covers both suspect drugs and concomitant medications including biologicals. In addition, the section can be used to identify drugs thought to have an interaction. For each drug, the characterization of the drug role (B.4.k.1) is that indicated by the primary reporter, (i.e., the original source of the information). The designation of "k" in this section indicates that each item is repeatable and that it carries an appropriate correspondence to the same "k" in all subsections. A separate block (k) should be used for each drug. The drug specified in the first iteration should be the one used in assessing the intervals in item B.2.i.7. Drugs used to treat the reaction/event should not be included here.

B.4.k.1 Characterization of drug role

Suspect/Concomitant/Interacting

User Guidance:

Characterization of the drug as provided by primary reporter. All spontaneous reports should have at least one suspect drug (see Section 1.5). If the reporter indicates a suspected interaction, "interacting" should be selected. All interacting drugs are considered to be suspect drugs.

B.4.k.2 Drug identification

User Guidance:

Drug substance name and/or proprietary medicinal product name should be provided as it was reported. In case of investigational drugs only a code may be known and provided. If more than one active substance is specified, each should be included as a separate drug in item B.4.k.2.2. and repeating the entire drug block (reiteration of "k") rather than as a repeating item B.4.k.2.2. An exception can be made when a proprietary medicinal product is provided in B.4.k.2.1, in which case the active substances can be specified as a repeating item in B.4.k.2.2.

B.4.k.2.1 Proprietary medicinal product name

User Guidance:

The name should be that used by the reporter. It is recognized that a single product may have different proprietary names in different countries, even when produced by a single manufacturer.

B.4.k.2.2 Active substance name(s)

User Guidance:

The INN(s) or drug substance name(s) or drug identification code(s) should be provided if no name exists. For combination products, each active ingredient should be specified. This information, as well as that requested for Proprietary medicinal product name (B.4.k.2.1) may not be known for concomitant or interacting drugs when the sender is a pharmaceutical company. In the case of blinded trials, in the exceptional circumstance when the blind has not been broken, the word "blinded" should precede the names of the drugs included in the study. Placebo can be included as a drug.

B.4.k.2.3 Identification of the country where the drug was obtained.

User Guidance:

See the companion document for the appropriate codes and format.

B.4.k.3 Batch/lot number

User Guidance:

This information is particularly important for vaccines and biologicals. The section allows for multiple batch/lot numbers, each separated by a delimiter defined by the transmission standard chosen. The most specific information available should be provided. For expiration date and other related information, see additional information on drug (B.4.k.19).

B.4.k.4 Holder and authorization/application number of drug

User Guidance:

If relevant and known, the name of the holder should be provided with the authorization number in the country where the drug was obtained when the case report is sent to that country. These items apply to both applications and authorizations. Pharmaceutical companies provide this information for their own suspect drug(s).

B.4.k.4.1 Authorization/Application Number

B.4.k.4.2 Country of authorization/application

User Guidance:

See the companion document for the appropriate codes and format.

B.4.k.4.3 Name of holder/applicant

B.4.k.5 Structured Dosage Information

(e.g., 2mg three times a day for five days)

B.4.k.5.1 dose (number)	2
B.4.k.5.2 dose (unit)	mg
B.4.k.5.3 number of separate dosages	3
B.4.k.5.4 number of units in the interval	1
B.4.k.5.5 definition of the interval unit	day
B.4.k.5.6 cumulative dose to first reaction (number)	30
B.4.k.5.7 cumulative dose to first reaction (unit)	mg

User Guidance:

Please note the above side-by-side illustration of how the structured dosage is provided. For the more complex example of 5mg (in one dose) every other day for 30 days, subsections B.4.k.5.1 through B.4.k.5.7 would be 5, mg, 1, 2, day, 75, mg, respectively. In the same way,

50 mg daily for 2 days would be 50, mg, 1, 1, day, 100, mg. For prolonged chronic therapy, the sender should consider the need to complete the cumulative dose sections.

The cumulative dose provided is the total dose administered until the first sign, symptom or reaction.

In the case of a parent-child/fetus report, the dosage section applies to the parental dose.

For dosage regimen that involve more than one dosage form and/or changes in dosage, the information should be provided in section B.4.k.6 as text. Alternatively, the sender can provide more than one iteration (k) for the same drug. Categories for "dose unit" and for "definition of the interval" are described in attachment 1.

B.4.k.6 Dosage text

User Guidance:

This item should be used in cases where provision of structured dosage information is not possible.

B.4.k.7 Pharmaceutical form (Dosage form)-

User Guidance:

e.g., tablets, capsules, syrup. free text until a controlled vocabulary is available.

B.4.k.8 Route of administration

User Guidance:

See suggested vocabulary in the route of administration list in attachment 2. For a parent-child/fetus report this indicates the route of administration of a drug given to the child/fetus. This is usually an indirect exposure such as transmammary but can include more usual routes of administration for other drugs given to the child. The parent's route of administration should be provided in B.4.k.9.

B.4.k.9 Parent route of administration (in case of a parent child/fetus report)

User Guidance:

This section should be used in a parent-child/fetus report and linked parent reports to indicate the route of administration to the parent.

B.4.k.10 Gestation period at time of exposure

User Guidance:

Use the gestational age at the time of the earliest exposure

Gestation period at time of exposure should be expressed by providing both a number and designation of units of days, weeks, months or trimester. See the companion document for format specifications.

B.4.k.11 Indication for use in the case

User Guidance:

The indication as reported. For multiple indications for the same drug, repeat the entire B.4.k block specifying the same drug for each indication. MedDRA terms should be provided as either text or code according to regional preferences until January 2003 when codes should be used in all regions. B.4.k.19 can be used to provide indications in other terminologies.

B.4.k.12 Date of start of drug

B.4.k.13 Time intervals between drug administration and start of reaction/event

User Guidance:

The major uses of intervals are to cover circumstances where both the dates are known but the interval is very short (e.g., minutes, such as in anaphylaxis), and when only imprecise dates are known but more information concerning the interval is known. Dates if available should always be transmitted in the appropriate items rather than intervals.

B.4.k.13 captures the interval between each drug and only the reaction/event in the first iteration of B.2.i. If there is more than one reaction/event and it is deemed necessary, more than one ICSR can be used to provide all the intervals between each suspect drug and all reactions/events. In this circumstance it is advisable to indicate the reports are linked in A.1.12. The complexity of the intervals highlights the desirability of providing dates. See the companion document for format specifications.

B.4.k.13.1 Time interval between beginning of drug administration and start of reaction/event

B.4.k.13.2 Time interval between last dose of drug and start of reaction/event

B.4.k.14 Date of last administration

User Guidance

For ongoing drug administration after the onset of the reaction/event, this item should be blank and Action(s) taken with drug (B.4.k.16) should be used.

B.4.k.15 Duration of drug administration

User Guidance:

This item should be used if exact dates of drug administration are not available at the time of the report, but there is information concerning the duration of drug administration. The information requested is the overall duration of drug administration and covers intermittent administration. See the companion document for the appropriate format.

B.4.k.16 Action(s) taken with drug

- *Drug withdrawn*
- *Dose reduced*
- *Dose increased*
- *Dose not changed*
- *Unknown*
- *Not applicable*

User Guidance:

These data, taken together with the outcome of the reaction (B.2.i.8), provide the information concerning dechallenge. "Not applicable" should be used in circumstances such as if the patient died or the treatment had been completed prior to reaction/event.

B.4.k.17 Effect of rechallenge (or re-exposure), for suspect drug(s) only

B.4.k.17.1 Did reaction recur on readministration?

-yes/no/unknown

User Guidance:

Unknown indicates that a rechallenge was done but it is not known if the event recurred. This segment should not be completed if it is unknown whether a rechallenge was done.

B.4.k.17.2 If yes to item B.4.k.17.1, which reaction(s)/event(s) recurred?

User Guidance:

Use MedDRA terms

B.4.k.18 Relatedness of drug to reaction(s)/event(s) (repeat B.4.k.18.1 through B.4.k.18.4 as necessary)

User Guidance:

This section provides the means to transmit the degree of suspected relatedness of each drug to the reaction(s)/event(s). The repeating items could also be used to provide the assessment of relatedness by different sources or methods of assessment. For the purpose of reporting, there is an implied suspicion of causality for spontaneous reports. It is recognized that information concerning the relatedness, especially for spontaneous reports, is often subjective and may not be available.

- The following example illustrates the extensive functionality contained in this section.
- Assume a patient being treated with two medications: Drug A and Drug B.
- Assume the patient has had three adverse events: Event 1, Event 2, and Event 3
- The reporter provided assessment of causality for events 1 and 2 for both Drug A and Drug B, but not for either drug concerning event 3. The reporter’s assessment of causality is based on overall impression which the sender codes as “global introspection”.
- The sender applies two methods of causality assessment, one with an algorithm (coded algorithm) and the other a bayesian analysis which provides a decimal probability (coded Bardi) but it does so only for the drug it manufactures (in this case Drug A).
- From the above there are 4 sets of data for the reporter (2drugsX2eventsX1method of assessment) and 6 sets for the sender (1drugX3eventsX2methods of assessment) for a total 10 sets of data.
- The appropriate item with the information is B.4.k.18 (and its four subfields 1-4). In this example k is replaced by Drug A and Drug B respectively. Please note the subfields 1-4 are repeatable. Thus:

B.4.k.18.1	B.4.k.18.2	B.4.k.18.3	B.4.k.18.4
k(1) = DRUG A			
event1	reporter	global introspection	related
event1	company	algorithm	possibly related
event1	company	Bardi	0.76
event2	reporter	global introspection	not related
event2	company	algorithm	possibly related
event2	company	Bardi	0.48
event3	company	algorithm	unlikely related
event3	company	Bardi	0.22
k(2) = DRUG B			

event1	reporter	global introspection	not related
event2	reporter	global introspection	not related

The order of the rows is not important since each one represents a complete set, however the E2B message and M2 specifications state that all assessments for Drug A (k=1) appear before Drug B (k=2).

For subsection B.4.k.18.1 MedDRA terms should be used. Subsections B.4.k.18.2 through B.4.k.18.4 do not require a controlled vocabulary.

B.4.k.18.1 Reaction assessed

User Guidance:

Generally the reactions assessed are ordered from the most important or the most serious to the least important.

B.4.k.18.2 Source of assessment (e.g. initial reporter, investigator, regulatory agency, company)

B.4.k.18.3 Method of assessment (e.g., global introspection, algorithm, Bayesian calculation)

B.4.k.18.4 Result

B.4.k.19 Additional information on drug

User Guidance:

This should be used to specify any additional information pertinent to the case that is not covered by above sections. (e.g., beyond expiration date, batch and lot tested and found to be within specifications). This item can also be used to provide additional information concerning the indication for the drug. Regional requirements may involve the use of a controlled vocabulary to provide the additional information concerning indication.

B.5 Narrative case summary and further information

B.5.1 Case narrative including clinical course, therapeutic measures, outcome and additional relevant information

User Guidance:

Focused, factual and clear description of the case should be given, including the words or short phrases used by the reporter.

B.5.2 Reporter's comments

User Guidance:

This item should be used to include the reporter's comments on the diagnosis, causality assessment or other issues considered relevant.

B.5.3 Sender's diagnosis/syndrome and/or reclassification of reaction/event

User Guidance:

This section provides the sender with an opportunity to combine signs and symptoms that were reported into a succinct diagnosis and the reasoning would be included in section B.5.4. MedDRA terminology.

B.5.4 Sender's comments

User Guidance

This section provides information concerning the sender's assessment of the case and can be used to describe disagreement with, and/or alternatives to the diagnoses given by the initial reporter.

3. GLOSSARY

Parent-child/fetus report: Report in which the administration of medicines to a parent results in a suspected reaction/event in a child/fetus.

Receiver: The intended recipient of the transmission.

Reporter: Reporter is the primary source of the information, (i.e., a person who initially reports the facts). This should be distinguished from the sender of the message, though the reporter could also be a sender.

Sender: The person or entity creating the message for transmission. Although the reporter and sender may be the same person, the function of the sender should not be confused with that of the reporter.

ATTACHMENT 1

Unit List

Mass

kg	kilogram(s)
g	gram(s)
mg	milligram(s)
µg	microgram(s)
ng	nanogram(s)
pg	picogram(s)
mg/kg	milligram(s)/kilogram
µg/kg	microgram(s)/kilogram
mg/m ²	milligram(s)/sq. meter
µg/ m ²	microgram(s)/ sq. meter

Volume

l	litre(s)
ml	millilitre(s)
µl	microlitre(s)

Radioactivity

Bq	becquerel(s)
GBq	gigabecquerel(s)
MBq	megabecquerel(s)
Kbq	kilobecquerel(s)
Ci	curie(s)
mCi	millicurie(s)
µCi	microcurie(s)
nCi	nanocurie(s)

Other

mol	mole(s)
mmol	millimole(s)
µmol	micromole(s)
iu	international unit(s)
kiu	iu(1000s)
Miu	iu(1,000,000s)
iu/kg	iu/kilogram
mEq	milliequivalent(s)
%	percent
gtt	drop(s)
DF	dosage form

User Guidance:

This is the suggested list of units. When using other units, transformation is recommended if possible. Otherwise the free text field should be used.

Definition of Interval List

Minutes
Hours
Days
Weeks
Months
Years
Cyclical
As necessary
Total

ATTACHMENT 2

Route of Administration List

Auricular (otic)	Intrasynovial
Buccal	Intratumor
Cutaneous	Intrathecal
Dental	Intrathoracic
Endocervical	Intratracheal
Endosinusial	Intravenous bolus
Endotracheal	Intravenous drip
Epidural	Intravenous (not otherwise specified)
Extra-amniotic	Intravesical
Hemodialysis	Iontophoresis
Intra corpus cavernosum	Nasal
Intra-amniotic	Occlusive dressing technique
Intra-arterial	Ophthalmic
Intra-articular	Oral
Intra-uterine	Oropharyngeal
Intracardiac	Other
Intracavernous	Parenteral
Intracerebral	Periarticular
Intracervical	Perineural
Intracisternal	Rectal
Intracorneal	Respiratory (inhalation)
Intracoronary	Retrobulbar
Intradermal	Subconjunctival
Intradiscal (intraspinal)	Subcutaneous
Intrahepatic	Subdermal
Intralesional	Sublingual
Intralymphatic	Topical
Intramedullar (bone marrow)	Transdermal
Intrameningeal	Transmammary
Intramuscular	Transplacental
Intraocular	Unknown
Intrapericardial	Urethral
Intraperitoneal	Vaginal
Intrapleural	

ATTACHMENT 3

Examples of how to populate fields relevant to identifying cases and their reports

The figure provides an example of how one would populate the fields relevant to identifying cases and their reports. Patient XX suffers three separate adverse events (AE1, AE2, AE3) spaced over a time period.

Example of a simple single report from a company to a regulator:

Hospital X reports AE1 to Company K who then in turn sends ICSR1 to Regulator. Population of relevant fields for this case is illustrated in the first row of the table. Company K populates A.1.0.1 with Company K's (case) safety report unique identifier "JP-K-001". Company K populates A.1.10.2 with "JP-K-001" because company K is the initial sender of the report. Because there has not been a previous E2B/M2 electronic report, the identifiers in A.1.0.1 and A.1.10.2 are the same.

Example of company to company to company to regulator transmission

Hospital X reports AE1 to Company B who then in turn sends ICSR2 to Company C. Population of relevant fields for this case is illustrated in the second row of the table. Company B populates A.1.0.1 with Company B's (case) safety report unique identifier "JP-B-001". Company B populates A.1.10.2 with "JP-B-001" because company B considers itself the initial sender of the report because it is unaware that Company K also sent an ICSR for this case.

Company C sends ICSR3 to Company D. The third row of the table indicates how Company C populates the relevant fields. Company C populates A.1.0.1 with "JP-C-001". Company C populates A.1.10.2 with "JP-B-001", leaving the field unchanged from the way Company B populated it. In addition, Company C populates A.1.11.1 (Source of the case identifier) with the name of company B, "B". A.1.11.2 is populated with Case Identifier in the Previous Transmission by Company B "JP-B-001".

Company D sends ICSR4 to Regulator. The fourth row of the table indicates how Company D populates the relevant fields. Company D populates A.1.0.1 with "JP-D-001". Company D retains in fields A.1.10.2, A.1.11.1, and A.1.11.2 the information populated by Company C, and Company D adds to the retained information in repeatable field A.1.11.1 "C" to represent that Company C is another source of the case identifier, and Company D adds in field A.1.11.2 "JP-C-001" to represent Company C's case identifier from the previous transmission.

Example of a simple single report with follow-up from a company to a regulator

Hospital X reports AE1 to Company E who then in turn sends ICSR5 to Regulator. Population of relevant fields for this case is illustrated in the fifth row of the table. Company E populates A.1.0.1 with Company E's (case) safety report unique identifier "JP-E-001". Company E populates A.1.10.2 with "JP-E-001" because company E is the initial sender of the report. Because to Company E's knowledge, there has not been a previous E2B/M2 electronic report, the identifiers in A.1.0.1 and A.1.10.2 are the same.

ICSR6 represents Hospital X's follow-up information about AE1 to Company E. Company E submits follow-up to ICSR5 to the regulator. The relevant fields, A.1.0.1 and A.1.10.2, are populated the same as for ICSR5. ICSR6, a follow-up report, is differentiated from ICSR5 by A.1.7, Date of Receipt of the Most Recent Information for this Report.

Example of Linking Two Separate Adverse Events Affecting the Same Patient

Patient XX later suffers a separate adverse event, AE2. Hospital X reports AE2 to Company K who then in turn sends ICSR7 to Regulator. Population of relevant fields for this new case is illustrated in the seventh row of the table. Company K populates A.1.0.1 with Company K's (case) safety report unique identifier "JP-K-002". Company K assigns a new (case) safety report unique identifier "JP-K-002" because "JP-K-001", as described above, represent a separate adverse event. Company K populates A.1.10.2 with "JP-K-002" because company K is the initial sender of the report. Because there has not been a previous E2B/M2 electronic report, the identifiers in A.1.0.1 and A.1.10.2 are the same. The previous report from Company K, "JP-K-001", for patient XX should be represented in A.1.12, Identification Number of the Report which is Linked to this Report.

In a contrasting example, Hospital X also reports AE2 to Company F. Company F had not previously received an AE concerning Patient XX, and therefore there is no linked report and A.1.12 is not populated. As in the first example concerning ICSR1, ICSR8 is a simple single report from a company to a regulator.

Example of Linking Three Separate Adverse Events Affecting the Same Patient

Patient XX later suffers a third, separate and distinct adverse event, AE3. Hospital Y reports AE3 to Company K who then in turn sends ICSR9 to Regulator. Population of relevant fields for this new case is illustrated in the ninth row of the table. Company K populates A.1.0.1 with Company K's (case) safety report unique identifier "JP-K-003". Company K assigns a new (case) safety report unique identifier "JP-K-003" because "JP-K-001" and "JP-K-002", as described above, represent separate, adverse events. Company K populates A.1.10.2 with "JP-K-003" because company K is the initial sender of the report. The previous reports from Company K, "JP-K-001" and "JP-K-002", for patient XX should be represented in the repeatable field A.1.12, Identification Number of the Report which is Linked to this Report.

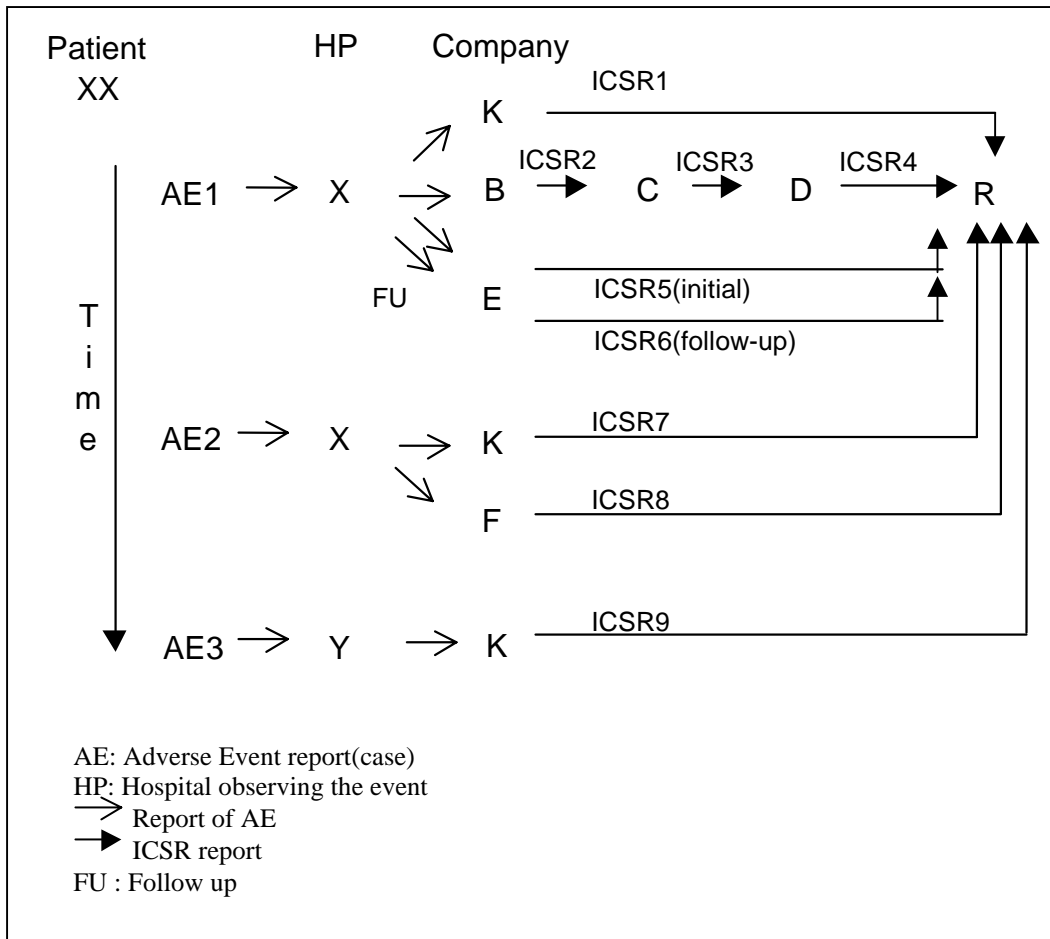

Tabular representation of fields contents for the above examples

	A.1.0.1.	A.1.10.2	A.1.11.1	A.1.11.2	A.1.12
ICSR1(K)	JP-K-001	JP-K-001			
ICSR2(B)	JP-B-001	JP-B-001			
ICSR3(C)	JP-C-001	JP-B-001	B	JP-B-001	
ICSR4(D)	JP-D-001	JP-B-001	B C	JP-B-001 JP-C-001	
ICSR5(E)	JP-E-001	JP-E-001			*
ICSR6(E)	JP-E-001	JP-E-001			*
ICSR7(K)	JP-K-002	JP-K-002			JP-K-001
ICSR8(F)	JP-F-001	JP-F-001			
ICSR9(K)	JP-K-003	JP-K-003			JP-K-001 JP-K-002

*These cases have different dates of most recent information (A.1.7)